



INSTALLATION GUIDE FOR THE RBL-TP1 Locks for Road King Classic® Tour Pack

Thank you for purchasing the INERTIA wrx RBL-TP1 security system for your tour pack. The following instructions will take you step by step through the installation process. Care should be taken at all times during the installation to protect the bag. A blanket or other soft surface should be used to prevent marring or scratching the leather. Take your time and follow the instructions to the letter.

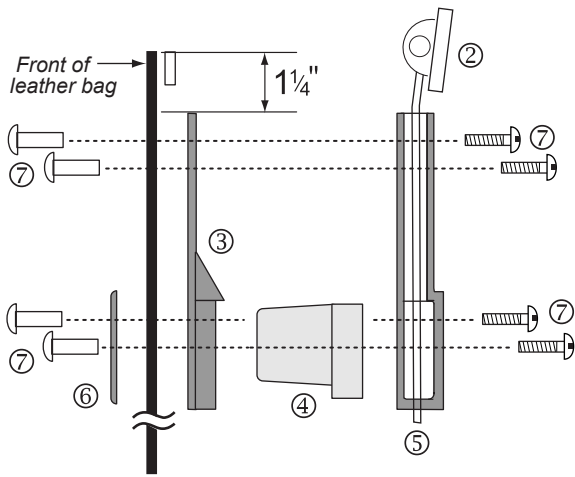

FIG 1. Sectional side view of lock assembly

- KIT CONTENTS**
- 1 ea. ② Ratchet bar assembly
 - 1 ea. ③ Ratchet bar guide
 - 1 ea. ④ Lock with 2 keys
 - 1 ea. ⑤ Lock keeper plate
 - 2 ea. ⑥ Lock cover plates
 - 6 ea. ⑦ Blind button cover screw sets

- TOOLS:**
- Drill and 1/4" drill bit, 3/4" step-drill or 3/4" hole punch #2
 - Phillips screwdriver and Wide flat blade screwdriver.

BECAUSE OF VARIATIONS IN THE BAGS, THE FINAL ALIGNMENT OF THE LOCK ON THE BAG IS NOT GUARANTEED TO BE AS SHOWN. PROBLEMS WITH THE LOCK SYSTEM ITSELF WILL BE ACCOMMODATED.

INSTALLATION

1. Close the bag completely. Support the outside of the bag with a covered piece of soft material to prevent marring or scratching.
2. Position the template on the outside of the bag, centered between the buckles. Align the template along the gap between the seams as shown at right. Tape the template in place.
3. Drill all of the small holes on the template using a 1/4" drill bit for the assembly holes. Drill or punch the 3/4" hole for the lock.
4. Sandwich the lock, item 4, between items 3 and 5 as shown above in FIG.1. Fasten it to the bag with the black slotted blind screws (items 7). Sandwich the leather between the lock cover plate (item 6) on the outside and the lock assembly. It may be necessary to remove a section of excess overlapped leather.
5. Use the phillips head screws (item 7) provided to attach the spring loaded ratched bar assembly.
6. Lock operation.
 - a. rotate the locking bar down as the bag is closed
 - so that it is started into the lock assembly.
 - b. check that the bag straps are outside of the bag.
 - c. Press the bag lid down as your help to align the bag lock assembly with the locking ratched bar. the ratchet bar will operate smoothly into the lock when properly aligned.

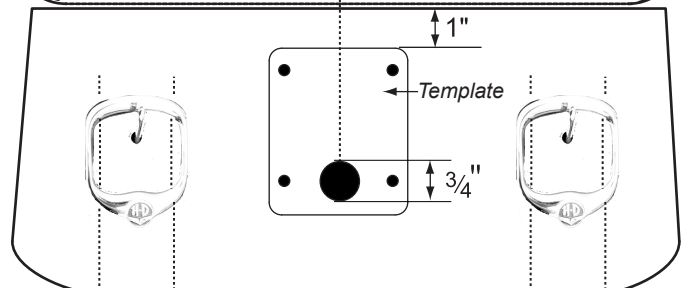
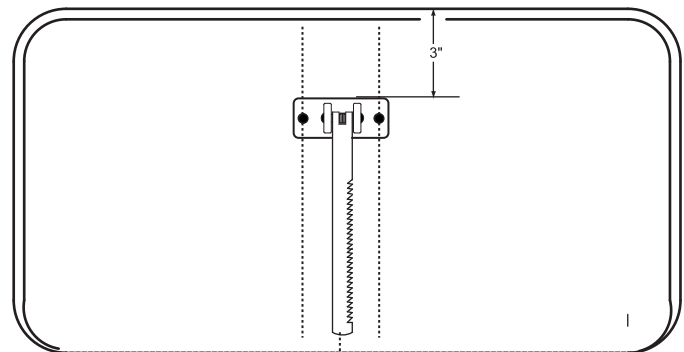
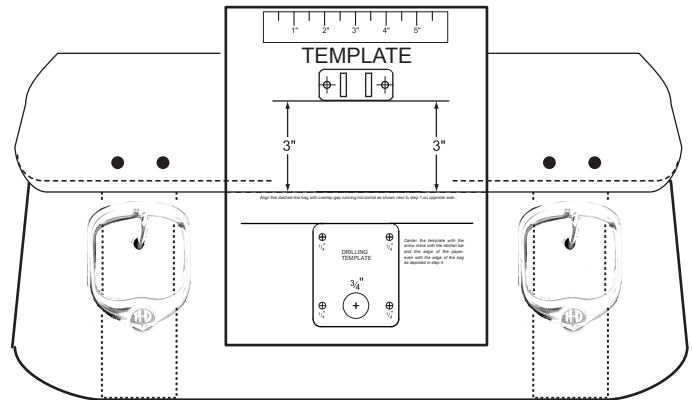

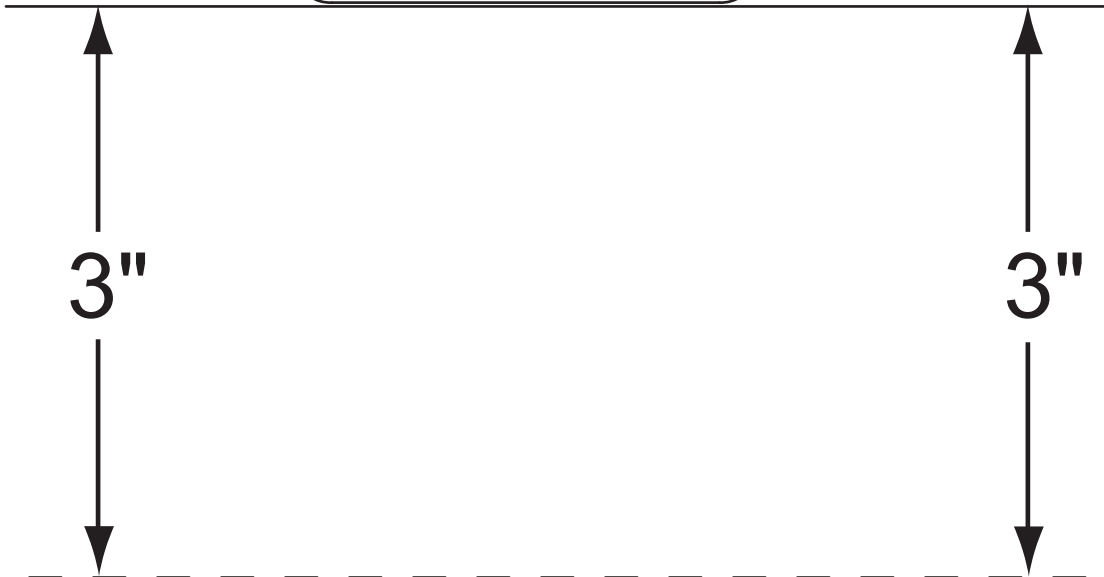
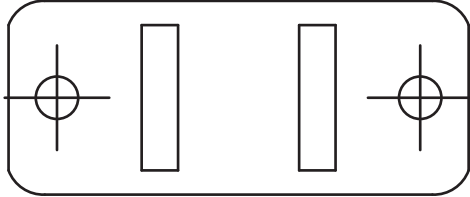
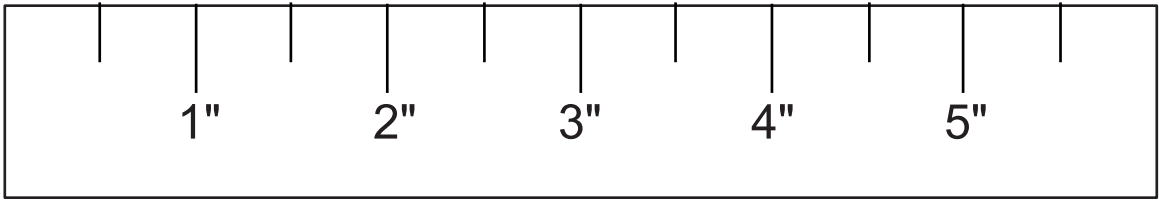

Align this dashed line bag with overlap gap running horizontal as shown next to step 1 on opposite side..

